



# AD Oracle iQ

FUME EXTRACTOR

A WORLD LEADER IN FUME EXTRACTION TECHNOLOGY

1. iQ display
2. On / off switch
3. Power cable
4. Signal / interface cable
5. Door hinge
6. Hose inlet connection - 75mm
7. Exhaust outlet
8. Motor cooling inlet
9. Door latch
10. Castors
11. Standby button

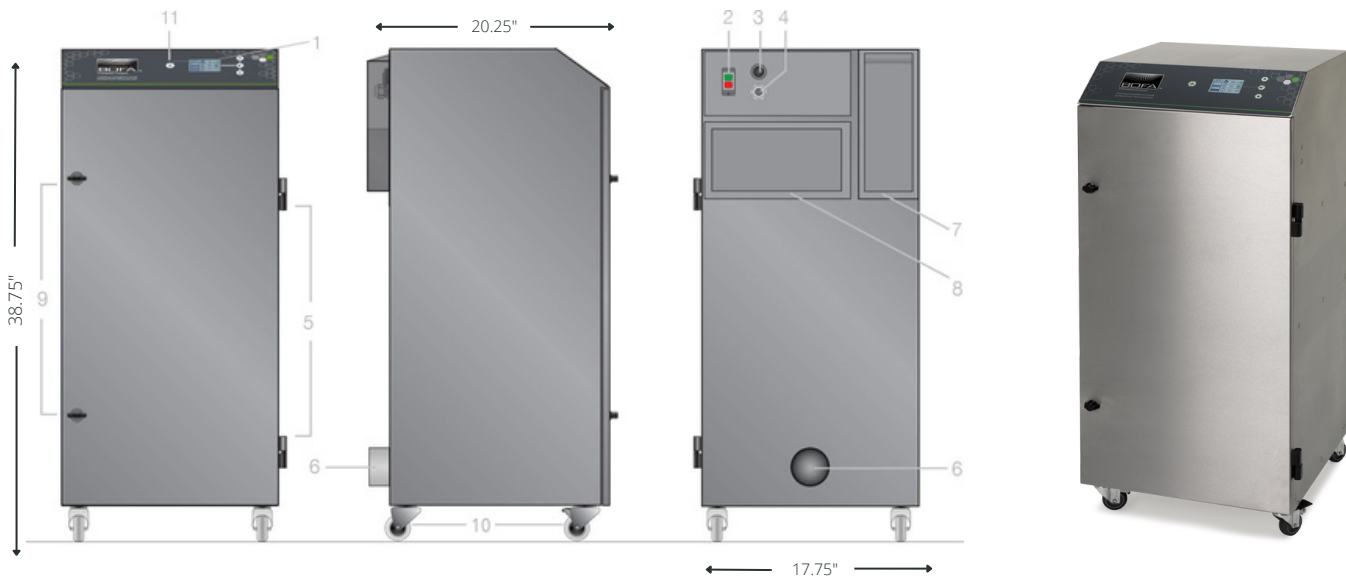

## TECHNICAL DATA

Technical data		Customisations
Dimensions (H x W x D)	38.75 x 17.75 x 20.25"	<b>Options</b> Stop / start function Filter signal condition VOC Blank plate / exhaust box / exhaust spigot
Unrestricted airflow*	241cfm (+/- 10%)	
Settable range**	59-224 cfm	<b>Paint finish</b> Brushed stainless steel Powder coated mild steel (RAL7016)
Max pressure	95mBar (+/- 10%)	
Electrical data	Voltage: 115-230V Frequency: 50/60Hz Full load current: 12.5 amps	If other options are required, please contact a sales representative
Interface signal connection	Not included as standard (see options for more information)	
Max noise level	< 85dBA	<b>Power cables</b> Type B Type E Type G Type free ends
Weight (standard extractor with filters)	143lbs (+/- 5%)	
Approvals	UKCA, CE and UL ***	

\* **Unrestricted airflow** = The airflow values provided with clean filters, no hose kit, at 230V, measured by using a wind vane. The numbers may vary depending on voltage and test procedure used.

\*\* **Settable range** = BOFA recommends utilizing the lowest flow rate that achieves the correct capture velocity for your application in order to maximise filter life

\*\*\* **UL** = Tested to UL standards, but testing may be provided by alternate nationally recognized test laboratories. Certain product configurations may affect the UL certification. Please speak to your sales representative.

Contact BOFA at <https://bofainternational.com/contact/>



FS 643451

Approvals: REACH and RoHS. See individual product technical data for specific accreditations



A Donaldson Company

# AD Oracle iQ

FUME EXTRACTOR

A WORLD LEADER IN FUME  
EXTRACTION TECHNOLOGY

## Airflow through filters

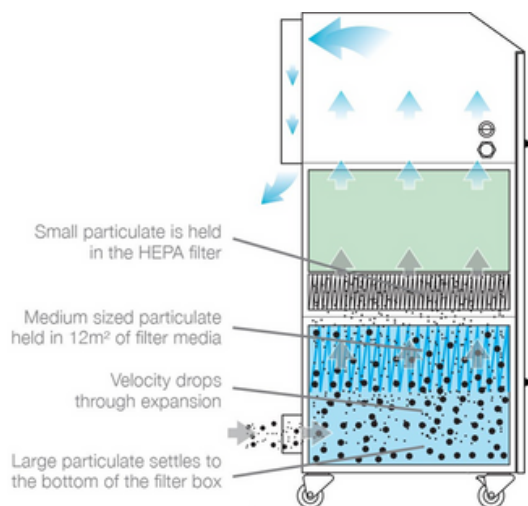

## FILTER SPECIFICATIONS

### DeepPleat DUO pre-filter specifications

Surface media area	12m <sup>2</sup> approx. (129.12ft <sup>2</sup> )
Filter efficiency	F8 - 50% @ 0.3 microns

### Combined filter specifications

HEPA filter efficiency	99.995% @ 0.3 microns
Activated carbon volume	4.12 gallons

### Replacement filters

Model	DeepPleat DUO pre-filter	Combined filter
AD Oracle iQ	1UA1030156	1UA1030155

Datasheet correct at time of publishing.

Where applicable, the carbon used in BOFA units is capable of removing a wide range of VOCs, however it is the responsibility of the user to ensure the carbon is suitable for their application. For specific applications, please contact us for details.

**Important notice:** Many factors beyond the control of BOFA can affect the use and performance of BOFA products in a particular application, including the conditions under which the product is used. Since these factors are uniquely within the user's knowledge and control, it is essential the user evaluate the products to determine whether the product is fit for the particular purpose and suitable for the user's application. All products, product specifications, availability and data are subject to change without notice, and may vary by region or country.

Think before you print! Please consider the environment before printing this document.